

## Simple fiber testers for the rapid expansion of GPON and XGS-PON networks

Everything is networked: people with people, people with machines and machines with machines. Everyone expects to be able to exchange ever-increasing amounts of data with anyone at any time from any location – mobile or not – in fractions of a second. For example, the integration of the AI platform ChatGPT, which creates artificial intelligence (AI) through machine learning, into the Bing search engine alone has increased the latter’s traffic by 15%. And other platforms are already waiting in the wings. The backbone, to which everyone is ultimately connected, has long since become inconceivable without high-performance fiber optic connections; speeds of 100 GigE are no longer unusual.

But how does this bandwidth get to where it is needed? How are small networks, companies, households, wifi networks, IoT devices, servers, smartphones, 5G mobile towers etc. connected to this backbone?

The answer is: through passive optical networks (so-called PONs). In recent years, this type of subscriber access via optical fiber has become increasingly popular worldwide, and continues to grow vigorously. Here’s what’s remarkable: 1 GigE-PONs (GPON) and 10 GigE-PONs (XGS-PON) can be operated in parallel on the same optical fiber lines. But this also entails new measuring challenges.

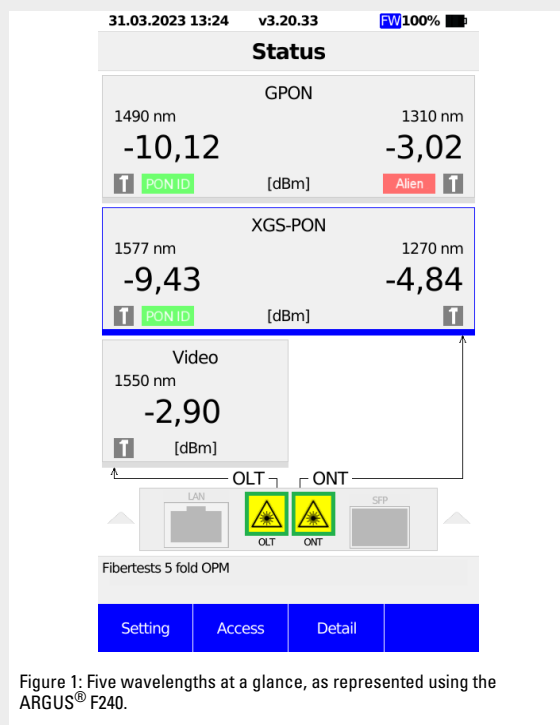

Figure 1: Five wavelengths at a glance, as represented using the ARGUS® F240.

### What are passive optical networks (PONs)?

GPON and XGS-PON are point-to-multipoint connections. The line is cascaded via passive optical splitters, and up to 64 subscribers can be connected to a single OLT port. All users downstream of this splitter share the bandwidth provided by the OLT, which is distributed to the individual users by means of time division multiplexing (TDM). According to ITU T G.984.3 (GPON), that adds up to a maximum of 2.5 Gbit/s in downstream and

1.25 Gbit/s in upstream. Just one single-mode optical fiber thus simultaneously transmits the downstream at a wavelength of 1490 nm and the upstream at 1310 nm.

Using wavelength division multiplexing (WDM), 10 Gbit/s can be transmitted simultaneously in both directions on this fiber according to ITU-T G.9807.1 (XGS-PON), and that in addition to GPON (see above). For this purpose, other wavelengths are used for downstream and upstream, both higher (1577 nm) and lower (1270 nm).

In addition, a video overlay for e.g. TV applications can be provided via 1550 nm – though only in the downstream direction.

This gives up to five wavelengths simultaneously on a single fiber.

### Level measurement in through mode

There are several ways to get the measure of these PONs. For example, OTDRs, which enable highly precise determinations about the condition of the optical fiber by evaluating the reflected pulse, are used most by a handful of experts. However, these always require expert knowledge, experience and a fine instinct. Especially in well-crafted new installations, with a few good-quality splices and no bending radius violations, OTDR measurements are usually not necessary and cost time.

Moreover, in terms of complexity and price alone, an OTDR that can measure up to five wavelengths simultaneously is no longer a suitable device for technicians who have to configure many accesses in a short time.

On the other hand, there are those who use simple and cheap broadband level meters and can thus determine the optical level for one wavelength; this works, is fast and cheap – but only when a single wavelength (e.g. GPON, 1490 nm, downstream) is to be measured! If the fiber carries more than one wavelength, the level of a single wavelength can no longer be reliably determined using a broadband OPM.

Nevertheless, optical level measurement is in principle the right way to quickly and easily obtain data that are easy to interpret. The passive splitters in particular often cause a considerable loss of power in PONs, and not always necessarily due to long distances, but rather to the splitting ratio of the splitters used and the total attenuation of all the connectors connected to them.

For instance, a 1:2 splitter attenuates the signal by half, i.e. by 3 dB, a 1:4 splitter by 6 dB and a 1:8 splitter by 9 dB. At 1:32, that already adds up to a loss of 15 dB. So the question in the end is always: Is the optical budget of the optical distribution network (ODN) class used (which determines, for example, the transmission power the OLT uses), e.g. B+, sufficient or not?

A level measurement is sufficient as long as it can be filtered (selective). This requires five separate filters, each with its own high-precision diode designed for the respective purpose. Thus, in

standard 1000BASE-BX10, which is most commonly used here, also uses the wavelengths 1310 nm (TX) and 1490 nm (RX).

In AONs, as in typical Ethernet connections, both sides have equal priority and can transmit continually. When an AON port of this type is connected to a PON, the light will interfere with the entire PON branch. Only a selective optical power meter with through mode and two separate upstream filters will be able to reliably detect and display this at runtime.

### Reading and resolving the PON ID

But quality five-fold OPMs (also called 5xOPM or 5λ-OPM, where λ stands for wavelength) do much more: they also immediately indicate whether the measurement is being conducted on the correct OLT port. To achieve this, the OLT transmits its PON ID, a port number unique to this OLT, to each ONT on this branch. Reading out and displaying the PON ID in conjunction with the level is the only way to be sure that you are really connected to the right branch. Especially in collocation spaces or other central distribution points, technicians can quickly lose track of connections. Poorly labelled fibers and the operation of remote stations of different network operators at the same location quickly increase complexity and pave the way for errors.

In such "crowded" circumstances, a 5xOPM equipped with a full GPON chip and fast diodes suitable for data transmission can even decode the PON ID and immediately indicate correct or incorrect assignment. The readout also provides the transmission power of the OLT and the insertion loss. From this, the attenuation on the line can also be derived. The ODN class and the use of repeaters can also be revealed. Broadband OPMs, OTDRs and even many selective OPMs often cannot do this.

In order to record all these measured values and information in a structured manner, some manufacturers use software wizards that ask the right questions depending on the customer topology and, in Germany for example, carry out an acceptance measurement (PON-FMT) according to ZTV43. All data are stored on the device and archived in clear measurement logs, which can be exported from the unit in various ways and formats.

### ONU ID/PLOAM scan

One particular advantage of selective OPMs that can resolve the PLOAM messages and read out the information from the ONT management and control interface (OMCI) channel is that users can also see the ONU ID communicated to the ONT.

Once a connection has been established at a free splitter port, the technician can force a resynchronisation of the branch and observe how the OLT reassigns ONU IDs to the incoming ONTs using a special PLOAM monitor or sniffer mode. This reveals whether all ONTs of an installation branch have been properly registered. An easily understandable trace then displays the status of all ONTs in a table; incorrectly connected devices can be detected and checked.

### Performance tests directly on the optical fiber

Once the xPON access has been tested and enabled, testing continues at higher protocol levels. In purely functional terms, the authentication as part of a PPP connection must be checked using the user name and password; also, the instrument must be able to test such services as video (IPTV) and/or telephony (VoIP). To enable this, however, the fiber tester must support a full ONT simulation. This is the only way to check the entire configuration of OLT and ONT, including transmission of the installation ID and reading out

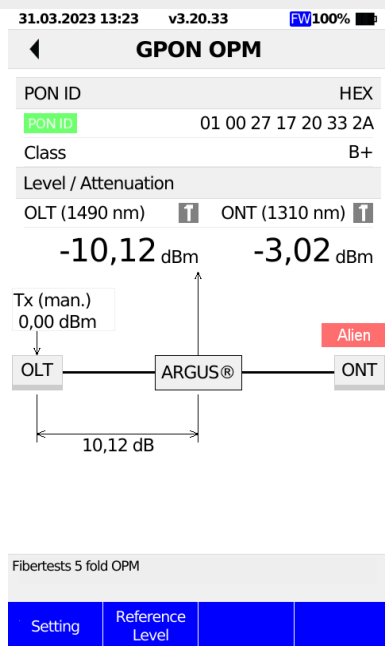

Figure 2: GPON downstream and upstream levels and section attenuation including alien detection, as represented using the ARGUS® F240.

upstream (1310 and 1270 nm) a rather irregular burst-like signal must be expected due to the TDM process, and a continuous transmission level of the OLT in the downstream (1490, 1550 and 1577 nm). However, in upstream, i.e. from the ONT, a response is only given if prompted by an OLT. Interrupting the line to measure the downstream level simultaneously disconnects and silences the ONT. The only way to also reliably measure the upstream level is therefore to loop into the line in a kind of through mode. This requires an instrument with two PON ports: one for the OLT side (down) and one for the ONT side (up). Particular care must be taken to influence the signal as little as possible. The insertion loss (IL) should not exceed 1.5 dB if at all possible.

And this is the only way to detect the different technologies (GPON, XGS-PON or both) and measure all important parameters in real time and without time-consuming plugging and unplugging of cables. This ensures that the technicians on site can obtain the information they need and indications of any potential problems.

### Alien detection

Passive optical networks (PONs) are widespread and increasingly displacing other technologies, but the latter may still be found. For example, there are the active optical networks (AON), which are usually point-to-point Ethernet connections based entirely on fiber optics and are often used by smaller network operators as FTTH products, e.g. to connect G.fast DSLAMs (so-called FTU-C) or in local networks and data centres. For instance, the Ethernet

the subscriber number via TR-069.

In the end, high bandwidths are paramount for fiber-optic accesses, but this performance can only be verified by means of high-performance speed tests. A normal FTP or HTTP up- or download with multiple parallel instances, ideally with respect to an own powerful server, provides an initial assessment. Alternatively, tests can be conducted using public or dedicated servers according to iperf or RFC 6349.

table attenuator.

Another important function is the ability to directly connect a suitable camera, which can be used to check the end face of the fiber to be connected for impurities, scratches or other defects. Such a fiber inspection tool performs a fully automated pass/fail evaluation according to IEC 61300-3-35 and detects particle sizes down to 0.5 µm. Even the smallest soiling or scratches in the core zone can lead to problems and quickly cause high bandwidth los-

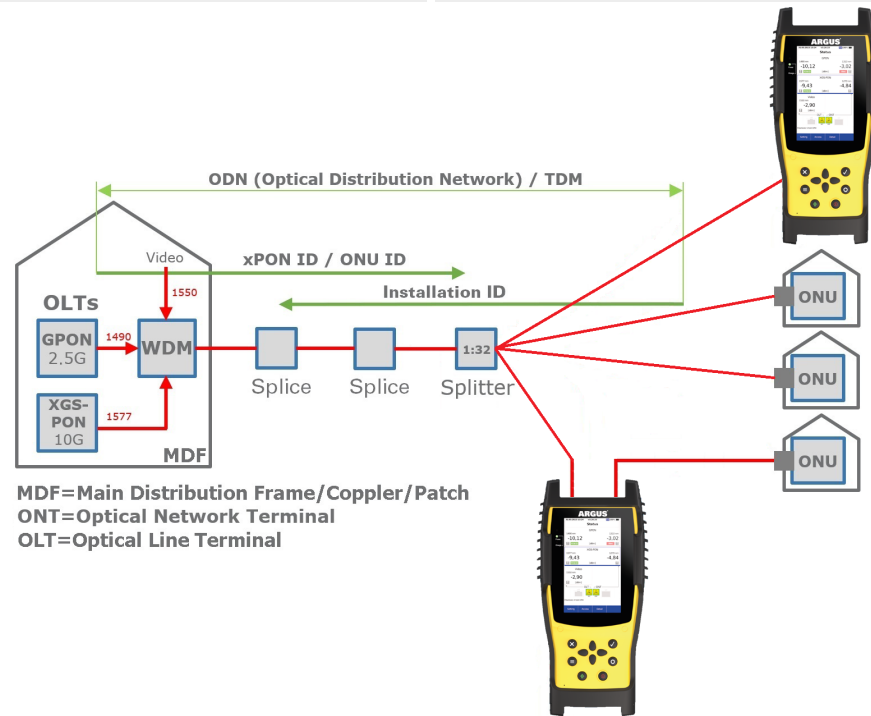

Figure 3: Using a special PLOAM monitor or sniffer mode, the technician can see how all ONU IDs are reassigned to the incoming ONTs by the OLT after resynchronization of the branch.

This is the only way to ensure that customers actually receive the bandwidth they have subscribed and are paying for. More and more often, even in the consumer segment, 1 Gbit/s accesses are increasingly being switched over; the future is 2 Gbit/s, in certain cases even 10 Gbit/s.

### Other features and functions

If the instrument also has a corresponding SFP slot that supports different Ethernet SFPs, level measurements can be carried out in digital diagnostic mode (DDM) according to SFF-8432, and services and performance can also be tested on AONs (see above).

A special GPON trace that time-stamps various important messages exchanged between OLT and ONT can, for example, reveal problems in the authentication process.

In principle, it is also always preferable to separate level measurement and ONT simulation to protect the instrument. For example, technicians are often unaware that the transmission level directly at the OLT (up to +15 dBm for XGS-PON, +5 dBm for GPON) can destroy sensitive receiving optics; after all, the light often has to overcome kilometre-long distances, splices and splitters. If it is possible to determine the level using the relatively sturdy optics of a level measurement function, then the instrument is clearly too close to the OLT. In this case, the ONT simulation can be connected safely via a separate socket with a sui-

ses to subsequently manifest. Simply touching the plug, leaving it lying around without a protective cap or just high humidity are often sufficient to negatively impact performance. Cleanliness is the top priority when commissioning and maintaining optical fiber accesses. Ideally, both end surfaces should be checked each time before plugging and cleaned if necessary. An auto-focus function can help to focus the core optimally and quickly.

### Conclusion and outlook

The fact remains that there is an enormous variety of optical fiber measurement technology on the market. In many cases, its usefulness depends greatly on the area of application. Some of these devices are intended for highly skilled experts who need to measure difficult and extremely complex fault types, while other, inexpensive solutions are certainly suitable for running quick checks. However, the great majority of technicians tasked with commissioning, servicing or troubleshooting accesses every day need a compact and affordable solution that can still detect the most common faults and problems more or less automatically.

One company offering instruments that meet this need is the metrology equipment manufacturer Intec, based in Lüdenscheid, Germany, with its ARGUS® brand devices. With the new ARGUS® F240, this German instrumentation specialist combines its many years of experience in the field of Ethernet and IP test

and measurement technology with the latest optical fiber technology in a single device. The result: selective level measurement of up to 5 wavelengths simultaneously, fully-fledged simulation of an ONT with all necessary protocols and the ability to conduct IP performance tests according to different methods and standards with up to 10 Gbit/s real throughput.

The future is sure to hold further surprises, for example, the first network operators in Germany and also in Europe are beginning to think about offering 10 GigE products - this would mean that a single XGS-PON access would be configured exclusively for just one end customer.



GESELLSCHAFT FÜR  
INFORMATIONSTECHNIK mbH

Rahmedestraße 90  
D-58507 Lüdenscheid

Tel: +49 2351 9070-0  
Fax: +49 2351 9070-70

E-Mail: [sales@argus.info](mailto:sales@argus.info)  
Internet: [www.argus.info/en](http://www.argus.info/en)

 [www.instagram.com/intec\\_argus](https://www.instagram.com/intec_argus)

 [www.facebook.com/intec.argus](https://www.facebook.com/intec.argus)

 ARGUS testing the telecom network

 <https://www.linkedin.com/company/441568>